

ITEM NO.	PART NUMBER	DESCRIPTION	Material	QTY.
1	BODY		C.I.	1
2	VALVE-SEAT		G.M.	1
3	VALVE		G.M.	1
4	COVER		C.I.	1
5	COVER-BUSH		Brass	1
6	SPINDLE		M.S.	1
7	TOGGLE		M.S.	1
8	Toggle-Pin	It Links LEVER to TOGGLE	M.S.	1
9	LEVER-GUIDE		M.S.	1
10	LEVER		F.S.	1
11	Fulcrum-Pin	it Links LEVER to COVER	M.S.	1
12	WEIGHT		C.I.	1
13	Lever-Pin	It Link WEIGHT to LEVER	M.S.	1
14	ISO 4018 - M20 x 40-WS			7

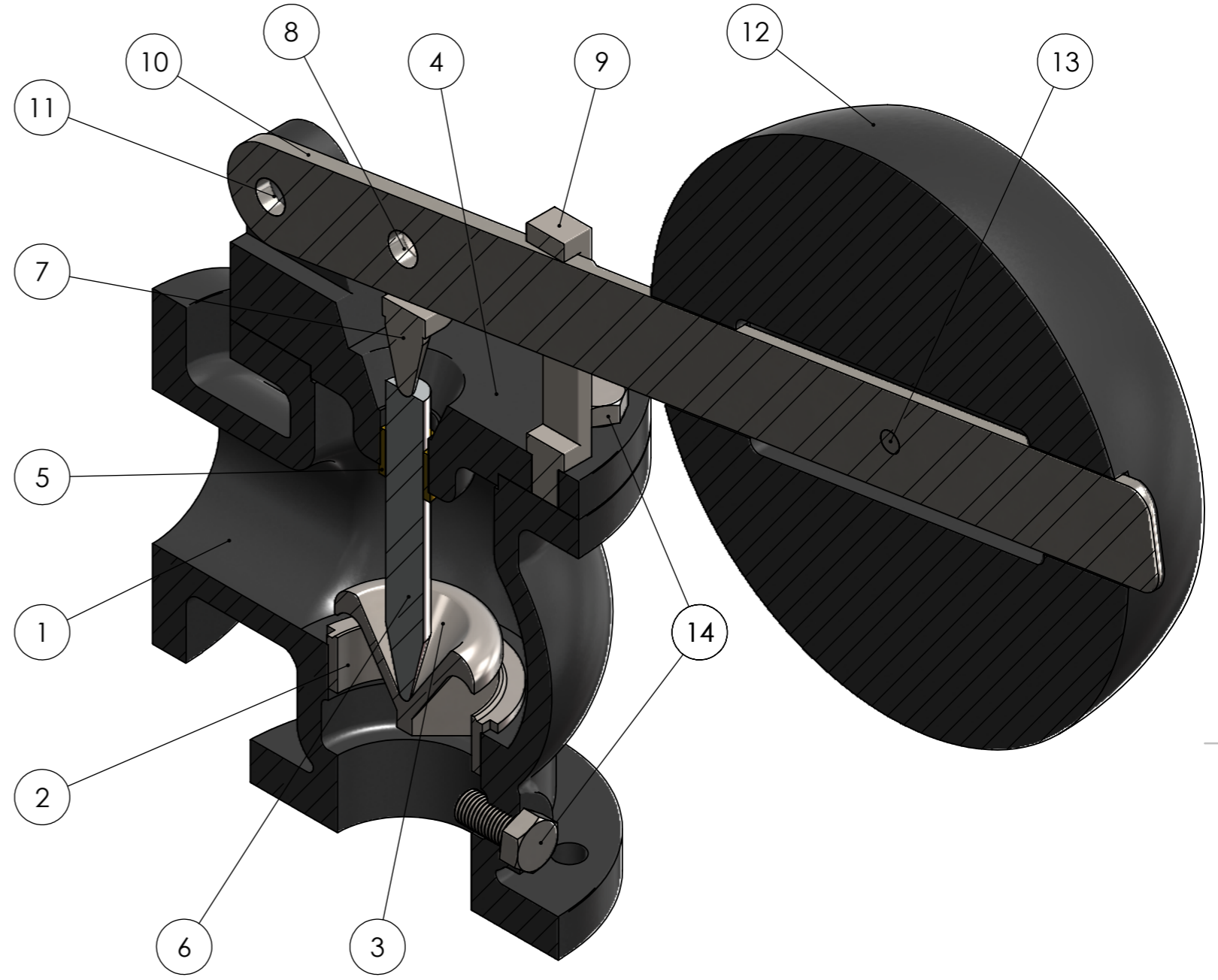

Abbreviation	Material
C.I.	Cast iron
G.M.	Gun Metal
M.S.	Mild Steel
F.S.	Forged steel

SECTION A-A
SCALE 1 : 3

UNLESS OTHERWISE SPECIFIED: DIMENSIONS ARE IN MILLIMETERS SURFACE FINISH: TOLERANCES: LINEAR: ANGULAR:			FINISH:		DEBURR AND BREAK SHARP EDGES		DO NOT SCALE DRAWING		REVISION		
DRAWN			NAME		SIGNATURE		DATE		TITLE:		
CHK'D											
APPV'D											
MFG											
Q.A									MATERIAL:		
									DWG NO.		
									LeverSafetyValve A3		
									SCALE:1:10		
									SHEET 1 OF 4		